

The universal videobar mount

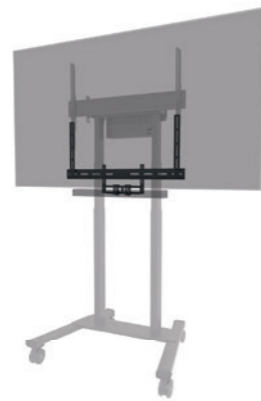

- For screens with a minimal size of 43" (VESA 200x200 - 800x600)
- Installation above or below the screen
- Suitable for wall, floor and even desk or ceiling mounts

- Compatible with most video- and soundbars
- Width and height adjustable VESA frame
- Ruler-guided alignment for a seamless screen installation



AV2-500BL
Screen size: 43-110"
Capacity: 10 kg
VESA: 200x200 - 800x600



AV2-500WH
Screen size: 43-110"
Capacity: 10 kg
VESA: 200x200 - 800x600

Suitable for:



AV2-500BL/WH

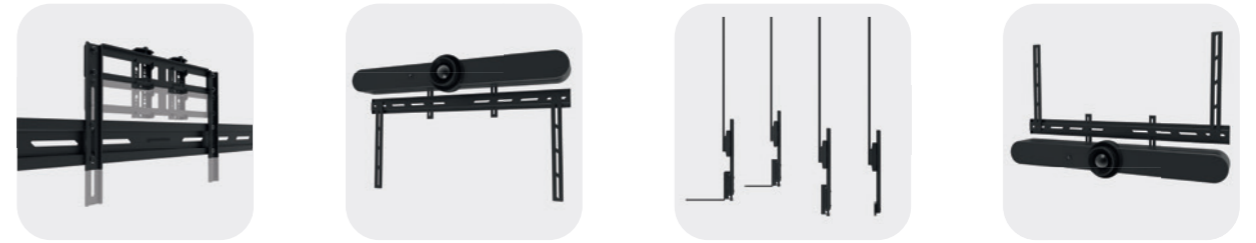

Compatible with most videobars, PTZ cams and soundbars, including Logitech Rally Plus speakers

Screen size: 43-110"

VESA: 200x200 - 800x600

Max. weight: 10 kg

Above or below the screen

Installable on wall, floor and even desk or ceiling mounts

VESA frame adjustable both in height and width (200/400/600/800)



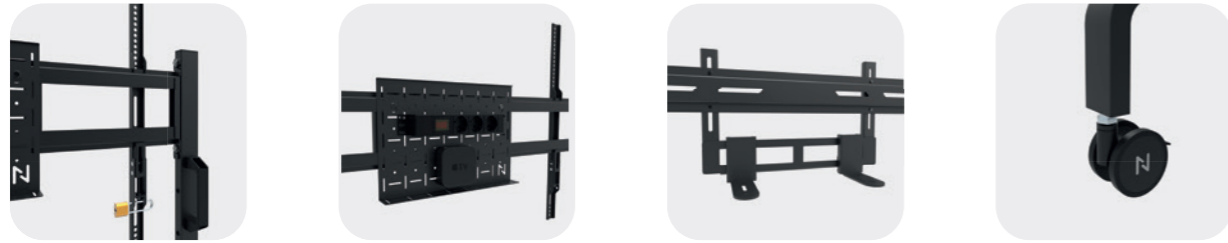

- Screens up to 86" (VESA 100x100 - 900x600)
- Installation can be done within just minutes
- Perfect solution also for touch screens due to sturdy design and touch screen stabilisers
- Manually adjustable in 4 preset height positions

- Practical handles
- Solid double locking caster wheels
- Multimedia shelf and AV hardware rack included
- Lockable brackets (padlock not included)
- Packed partially pre-assembled



FL50-525BL1
Screen size: 55-86"
Capacity: 76 kg
Height: 106-136 cm



FL50-525WH1
Screen size: 55-86"
Capacity: 76 kg
Height: 106-136 cm



Accessories: **AV2-500BL/WH:** Universal videobar kit
ABL-875: Caster brake lock



- Screens up to 110" (VESA 200x200 - 1100x600)
- Installation can be done within just minutes
- Perfect solution also for large and ultra-wide 105" (touch) screens due to sturdy design
- Manually adjustable in 2 preset height positions
- Multimedia shelf and lockable hardware compartment included

- Practical handles
- Solid double locking caster wheels
- Wide base for easy (touch) screen access
- Lockable brackets (padlock not included)
- Low depth profile for easy doorway passage
- Packed partially pre-assembled



FL50-575BL1
Screen size: 65-110"
Capacity: 125 kg
Height: 129-139 cm



FL50-575WH1
Screen size: 65-110"
Capacity: 125 kg
Height: 129-139 cm



Accessories:

AV2-500BL/WH:	Universal videobar kit
AWL-250BL18:	VESA 800 extension kit
ABL-875:	Caster brake lock





- Screens up to 75" (VESA 100x100 - 600x400)
- Manually adjustable in height
- Lockable hardware compartment included
- Practical height adjustable handles
- Solid double locking caster wheels or floor plate
- Lockable brackets (padlock not included)
- Internal cable management with various in & out outlets
- Compactly packed



FL50S-825BL1
Screen size: 37-75"
Capacity: 70 kg
Height: 104-157 cm



FL50S-825WH1
Screen size: 37-75"
Capacity: 70 kg
Height: 104-157 cm



FL45S-825BL1
Screen size: 37-75"
Capacity: 70 kg
Height: 104-157 cm



Accessories: **AFLS-825BL1/WH1:** Cam & multimedia kit incl. Logitech adapter
AV2-500BL/WH: Universal videobar kit
ABL-875: Caster brake lock



- Screens up to 100" (VESA 100x100 - 800x600)
- Motorised adjustable in height (35 mm/sec)
- Lockable hardware compartment included
- Practical handles
- Wired remote control

- Anti-collision system for extra safety
- Solid double locking caster wheels or floor plate
- Lockable brackets (padlock not included)
- Cable management
- Partially pre-assembled and compactly packed

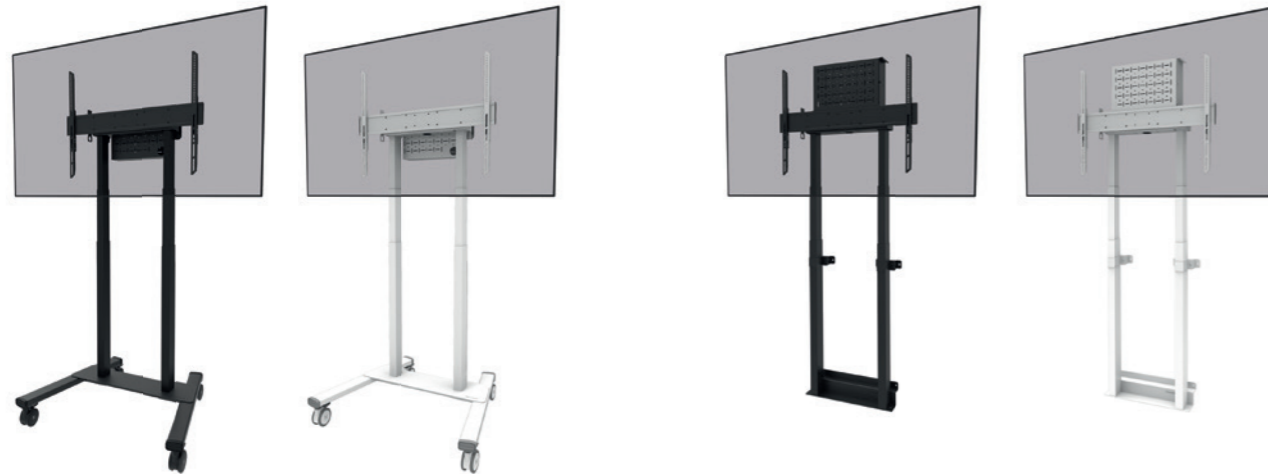

FL55-875BL1
Screen size: 55-100"
Capacity: 110 kg
Height: 111,3-176,3 cm

FL55-875WH1
Screen size: 55-100"
Capacity: 110 kg
Height: 111,3-176,3 cm

WL55-875BL1
Screen size: 55-100"
Capacity: 110 kg
Height: 98-163 cm

WL55-875WH1
Screen size: 55-100"
Capacity: 110 kg
Height: 98-163 cm

Accessories:

- AFL-875BL1/WH1:**
- AV2-500BL/WH:**
- ADM-875BL2/WH2:**
- AFP-875BL/WH:**
- ABL-875:**

- Cam & multimedia kit incl. Logitech adapter
- Universal videobar kit
- Dual screen adapter
- Floor plate
- Caster brake lock



LEVEL | 750



Range specification

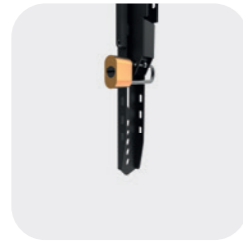

Fixed

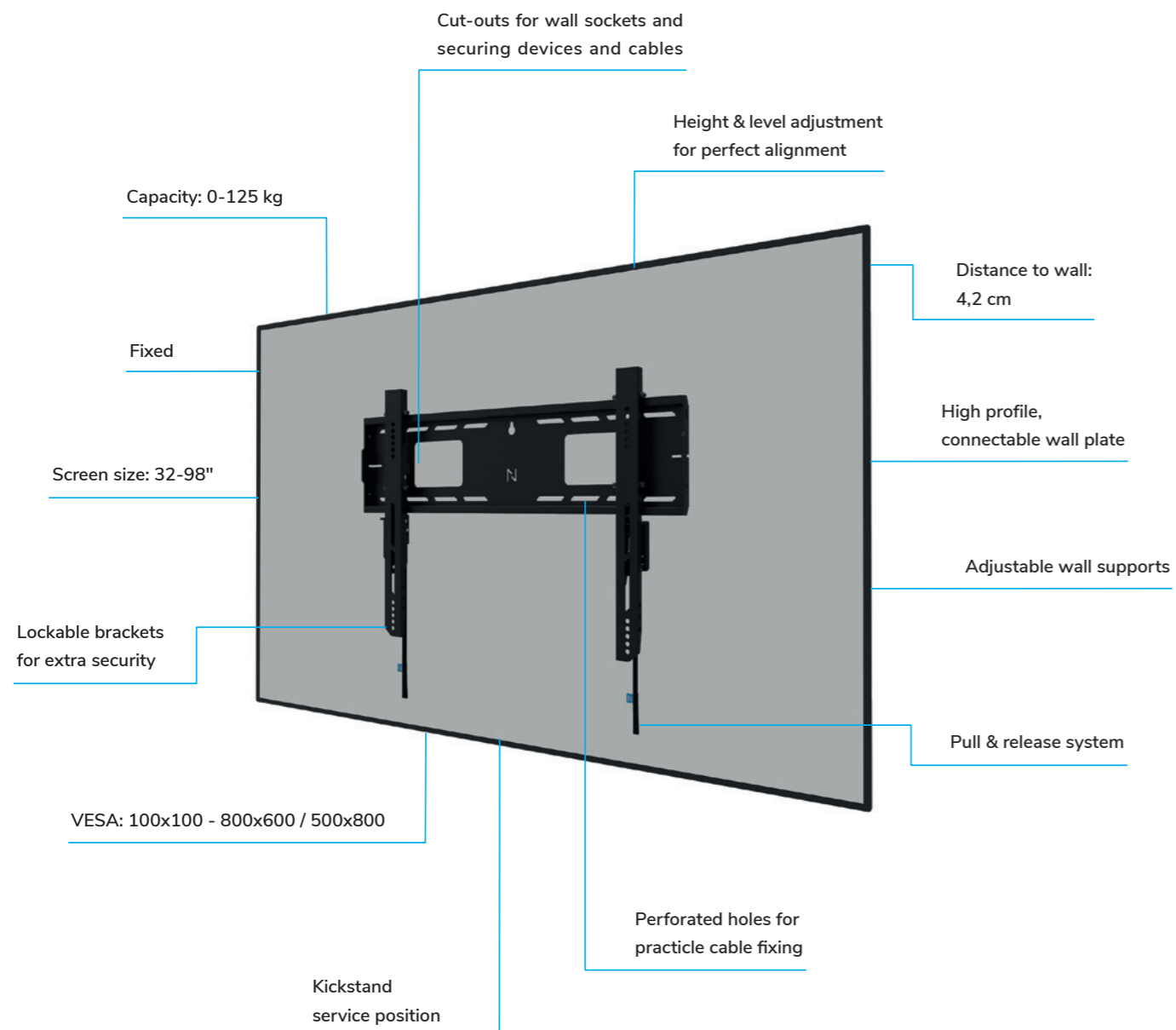

LEVEL | 750



- Screens up to 98" (VESA 100x100 - 800x600)
- Steel high profile heavy-duty wall plate
- Pull & release system for easy screen installation
- Level adjustment for perfect alignment
- Individual height adjustable brackets with cable storage

- Slim 4,2 cm profile
- Portrait model available (VESA 100x100 - 500x800)
- Mountable even on uneven wall surfaces
- Lockable brackets for extra security
- Kickstand service position for easy access
- Connectable wall plate for multiple screen mounting



WL30-750BL14
Screen size: 32-75"
Capacity: 100 kg
VESA: 100x100 - 400x400

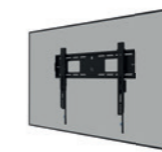

WL30-750BL16
Screen size: 42-86"
Capacity: 125 kg
VESA: 100x100 - 600x400



WL30-750BL18
Screen size: 43-98"
Capacity: 125 kg
VESA: 100x100 - 800x600



WL30-750BL18P
Screen size: 50-98", portrait
Capacity: 100 kg
VESA: 100x100 - 500x800



AWL05-750BL
AV hardware rack
Capacity: 10 kg
For Apple-TV, mini-PC, NUC and more
Suitable as backplate connector for multiple screen setup

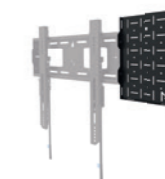

AV2-500BL/WH
Universal videobar kit





- Screens up to 98" (VESA 100x100 - 800x600)
- Tilt function for optimal viewing position
- Steel high profile heavy-duty wall plate
- Pull & release system for easy screen installation
- Individual height adjustable brackets with cable storage

- Mountable even on uneven wall surfaces
- Level adjustment for perfect alignment
- Lockable brackets for extra security
- Tilt lock for safe installation
- Connectable wall plate for multiple screen mounting

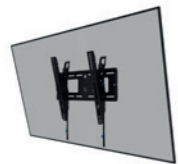

WL35-750BL14
Screen size: 32-75"
Tilt: +15°-15°
Capacity: 100 kg
VESA: 100x100 - 400x400

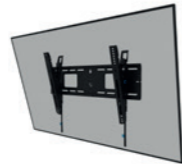

WL35-750BL16
Screen size: 42-86"
Tilt: +15°-15°
Capacity: 125 kg
VESA: 100x100 - 600x400



WL35-750BL18
Screen size: 43-98"
Tilt: +15°-15°
Capacity: 125 kg
VESA: 100x100 - 800x600



AWL05-750BL
AV hardware rack
Capacity: 10 kg
For Apple-TV, mini-PC, NUC and more
Suitable as backplate connector for multiple screen setup



AV2-500BL/WH
Universal videobar kit

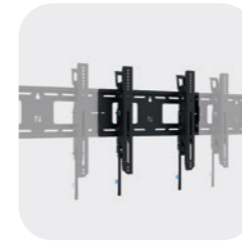

Range specification

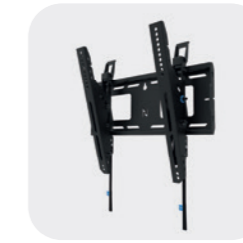
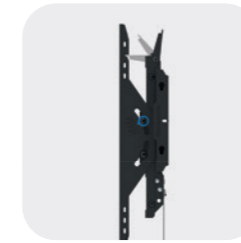

Tilt

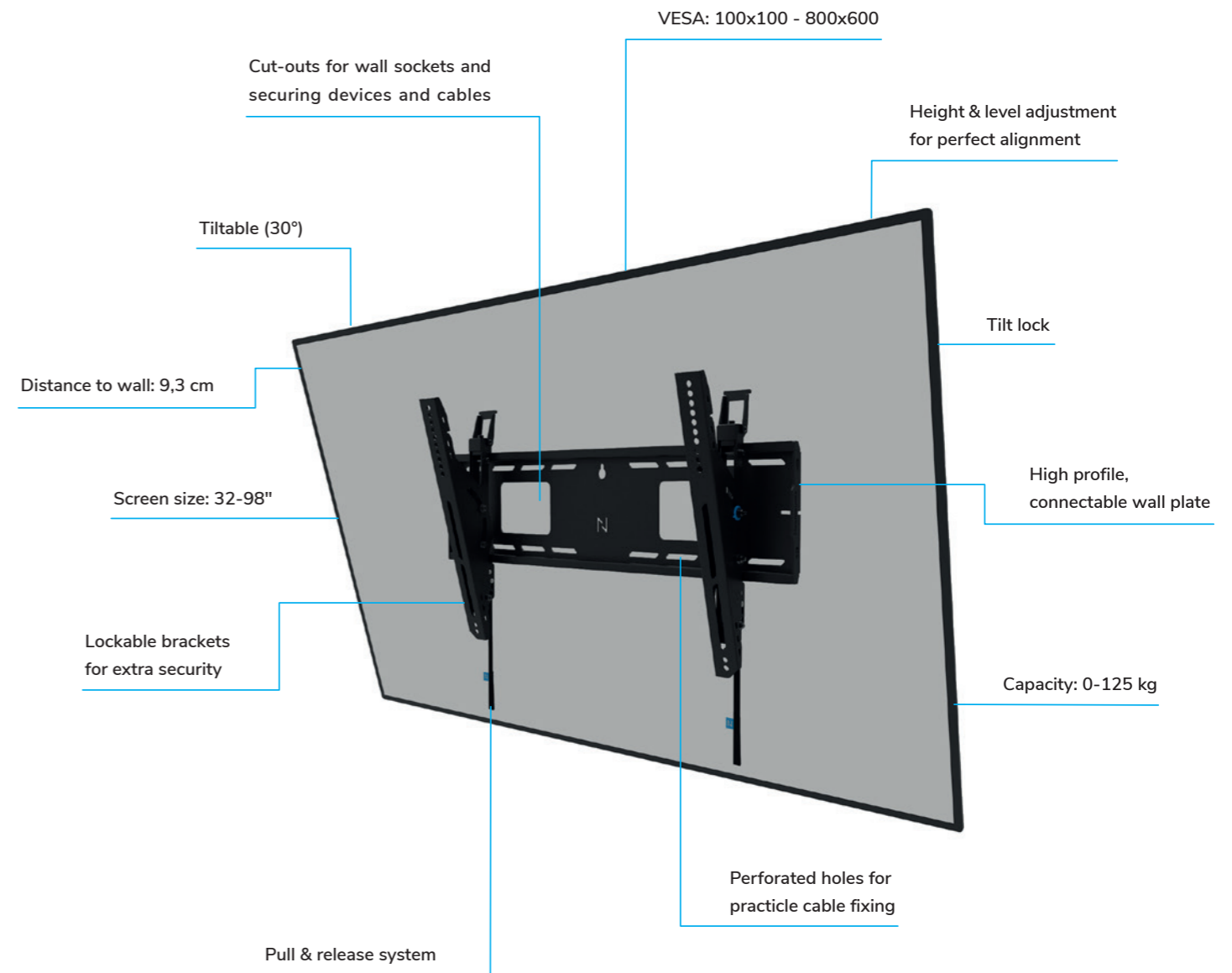

Neomounts offers the most comprehensive, up-to-date assortment of high-quality mounting solutions, according to the latest trends in the AV and IT market.

The products in the assortment of Neomounts are designed with an eye for detail, quality, value for money and ease of installation. Our mission is that you always experience the best viewing and working position, resulting in optimal posture and maximum comfort whilst using your screen.

With over 25 years of experience, Neomounts offers the best mounting solutions for you and your customers. The products are available worldwide through an extensive network of distributors and resellers in the Office, IT and AV channels.

We offer the best support for your business with:

- > Local sales support
- > Special bid price support for large projects
- > Demo units
- > Fast delivery
- > 5 year warranty

We rise by lifting others

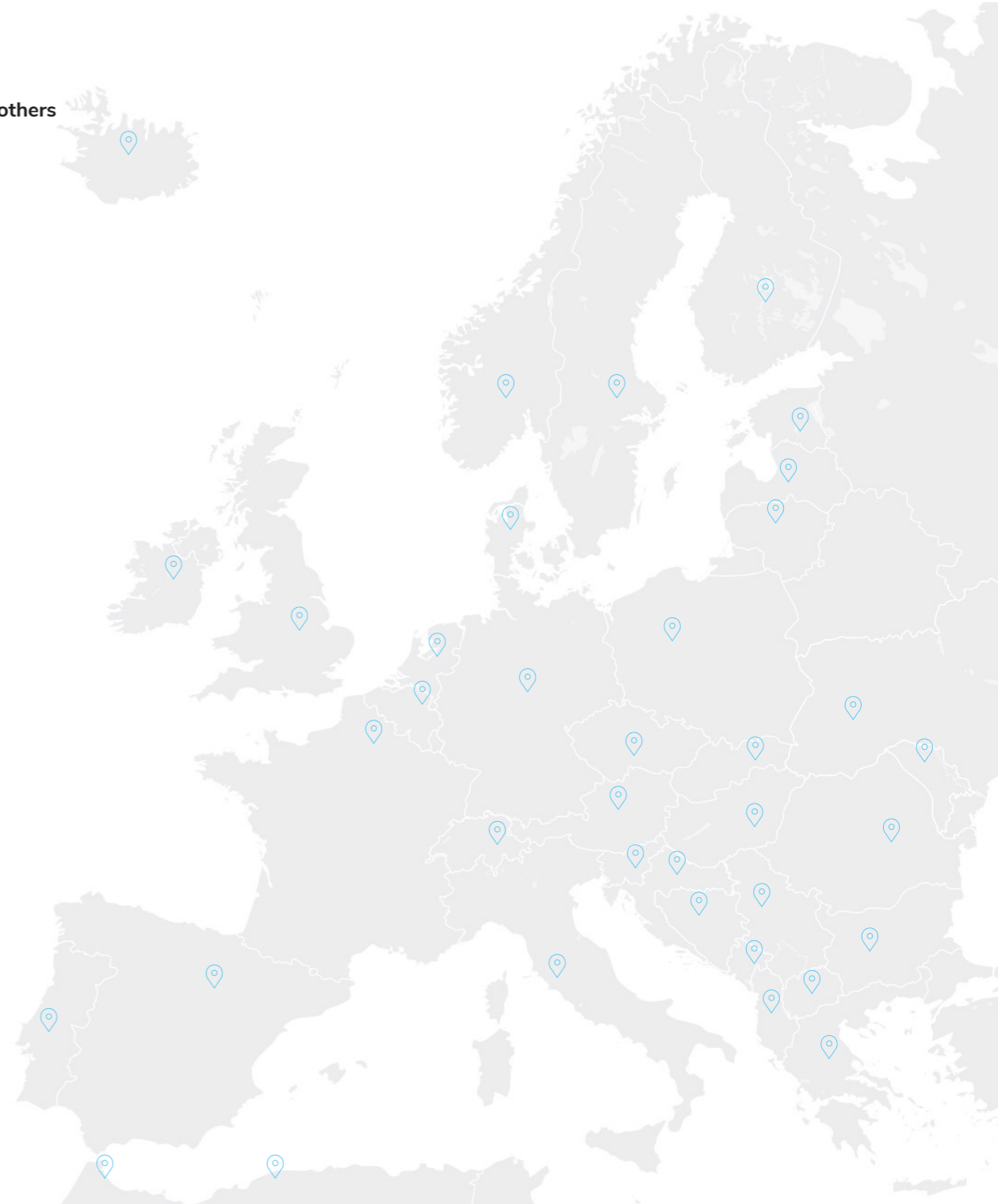

Questions? Don't hesitate to contact us on telephone number +31(0)23-5478888 or email sales@neomounts.com.

TÜV certification

The TÜV certification is globally recognized as proof of safety and quality, ensuring products have been rigorously tested for safety and comply with the relevant technical and safety requirements. This includes documentation review, performance assessment and (laboratory) testing. An over-load test with 5 times the allowed maximum weight is part of this testing process.

TÜV conducts regular inspections, to ensure products initially tested and certified by TÜV continue to be produced with consistent quality. Included are production inspections, supplier assessment and pre-delivery inspections.

As an independent body, TÜV certification serves as acknowledgement of quality and reliability.



© All rights reserved. Whilst every effort has been made to ensure the accuracy of the information in this brochure, Neomounts cannot be held responsible for any inaccuracies, errors or omissions. The images and information are subject to change and not binding.



Neomounts is part of the Global Mounts Group, that offers the most extensive range of advanced mounting solutions for professional AV and IT applications.

